

Application News

No. AD-0081

Forensic Analysis / On-line SPE LCMS-2020

**Simultaneous Screening and Quantitation of
Amphetamines in Urine by On-line SPE-LC/MS Method**

ASMS 2014 ThP587

Helmy Rabaha¹, Lim Swee Chin¹, Sun Zhe²,
Jie Xing² & Zhaoqi Zhan²

¹Department of Scientific Services, Ministry of Health,
Brunei Darussalam;

²Shimadzu (Asia Pacific) Pte Ltd, Singapore, SINGAPORE

Simultaneous Screening and Quantitation of Amphetamines in Urine by On-line SPE-LC/MS Method

Introduction

Amphetamines belong to stimulant drugs and are also controlled as illicit drugs worldwide. The conventional analytical procedure of amphetamines in human urine includes initial immunological screening followed by GCMS confirmation and quantitation [1]. With new SAMHSA guidelines effective in Oct 2010 [2], screening, confirmation and quantitation of illicit drugs including amphetamines were allowed to employ LC/MS and LC/MS/MS, which usually does not require a derivatization step as used in the GCMS method [1]. The objective of this study was to develop an on-line SPE-LC/MS method for

analysis of five amphetamines in urine without sample pre-treatment except dilution with water. The compounds studied include amphetamine (AMPH), methamphetamine (MAMP) and three newly added MDMA, MDA and MDEA by the new SAMHSA guideline (group A in Table 1). Four potential interferences (group B in) and PMPA (R) as a control reference were also included to enhance the method reliability in identification of the five targeted amphetamines from those structurally similar analogues which potentially present in forensic samples.

Experimental

The test stock solutions of the ten compounds (Table 1) were prepared in the toxicology laboratory in the Department of Scientific Services (MOH, Brunei). Five urine specimens were collected from healthy adult volunteers. The urine samples used as blank and matrix to prepare spiked amphetamine samples were not pre-treated off-line by any means except dilution of 10 times with pure water. An on-line SPE-LC/MS was set up on the LCMS-2020, a single quadrupole system, with a switching valve and a trapping column kit (Shimadzu Co-Sense configuration) installed in the column oven and controlled by the LabSolutions workstation. The analytical column used was Shim-pack VP-ODS 150 x 2mm (5 μ m) and the trapping column was Synergi Polar-RP 50 x 2mm (2.5 μ m), instead of

a normal SPE cartridge. The injected sample first passed through the trapping column where the amphetamines were trapped, concentrated and washed by pure water for 3 minutes followed by switching to the analytical flow line. The trapped compounds were then eluted out with a gradient program: 0.01min, valve at position 0 & B=5%; 3 min, valve at position 1; 3.01-10 min, B=5% \rightarrow 15%; 10.5-12 min, B=65%; 12.1 min, B=5%; 14 min stop, valve to position 0. The mobile phases A and B were water and MeOH both with 0.1% formic acid and mobile C was pure water. The total flow rates of the trapping line and analytical line are 0.6 and 0.3 mL/min, respectively. The injection volume was 20 μ L in all experiments.

Simultaneous Screening and Quantitation of Amphetamines in Urine by On-line SPE-LC/MS Method

Table 1: Amphetamines & relevant compounds

No	Name	Abbr. Name	Formula	Structure
A1	Amphetamine	AMPH	C ₉ H ₁₃ N	
A2	Methamphetamine	MAMP	C ₁₀ H ₁₅ N	
A3	3,4-methylene-dioxyamphetamine	MDA	C ₁₀ H ₁₃ NO ₂	
A4	3,4-methylene-dioxymethamphetamine	MDMA	C ₁₁ H ₁₅ NO ₂	
A5	3,4-methylene diox-N-ethyl amphetamine	MDEA	C ₁₂ H ₁₇ NO ₂	
B1	Nor pseudo-ephedrine	Nor pseudo-E	C ₉ H ₁₃ NO	
B2	Ephedrine	Ephe	C ₁₀ H ₁₅ NO	
B3	Pseudo-Ephedrine	Pseudo-E	C ₁₀ H ₁₅ NO	
B4	Phentermine	Phent	C ₁₀ H ₁₅ N	
R	Propyl-amphetamine	PAMP	C ₁₂ H ₁₉ N	

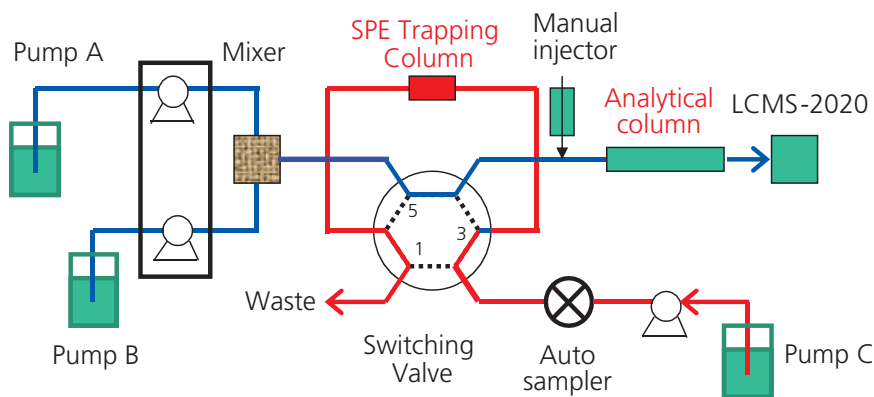

Figure 1: Schematic diagram of on-line SPE-LC/MS system

Simultaneous Screening and Quantitation of Amphetamines in Urine by On-line SPE-LC/MS Method

Results and Discussion

Development of on-line SPE-LC/MS method

With ESI positive SIM and scan mode, all of the 10 compounds formed protonated ions $[M+H]^+$ which were used as quantifier ions. The scan spectra were used for confirmation to reduce false positive results. Mixed standards of the ten compounds in Table 1 spiked in urine was used for method development. An initial difficulty encountered was that the normal reusable SPE cartridges

(10-30 mL) for on-line SPE could not trap all of the ten compounds. With using a 50mmL C18-column to replace the SPE cartridge, the ten compounds studied were trapped efficiently. Furthermore, the trapped compounds were well-separated and eluted out in 8~13 minutes as sharp peaks (Figure 2) by the fully automated on-line SPE-LC/MS method established.

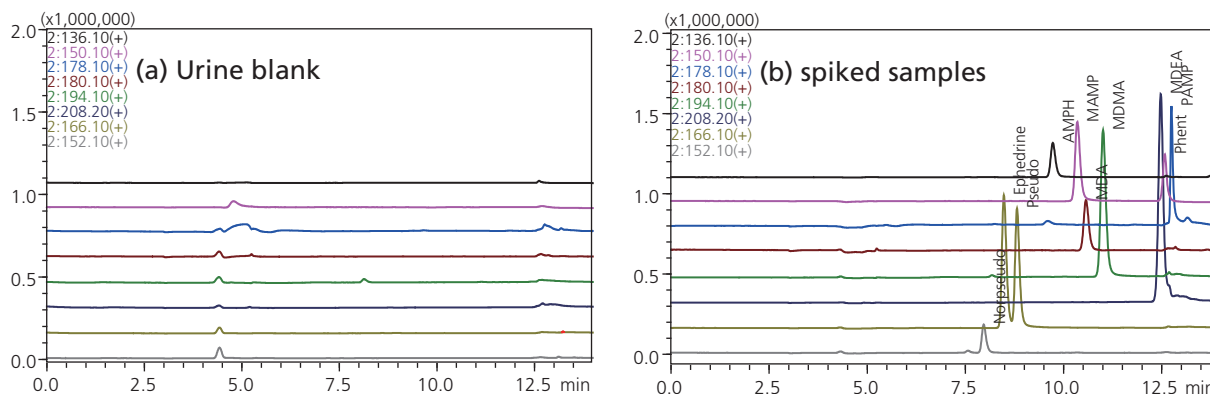

Figure 2: SIM chromatograms of urine blank (a) and five amphetamines and related compounds (125 ppb each) spiked in urine (b) by on-line SPE-LC/MS.

Calibration curves of the on-line SPE-LC/MS method were established using mixed standard samples with concentrations from 2.5 ppb to 500 ppb. Linear calibration

curves with $R^2 > 0.999$ were obtained for every compound (Figure 3 & Table 2).

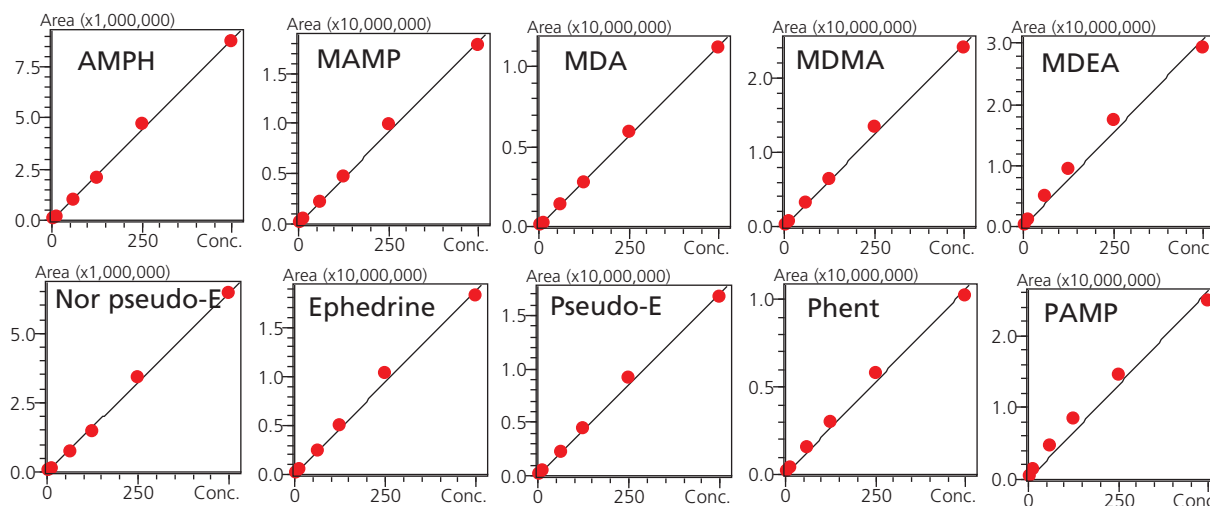

Figure 3: Calibration curves of five amphetamines and five related compounds with concentrations from 2.5 ppb to 500 ppb by on-line SPE-LC/MS method

Simultaneous Screening and Quantitation of Amphetamines in Urine by On-line SPE-LC/MS Method

Table 2: Peak detection, retention, calibration curves and method performance evaluation

Name	SIM ion (+)	RT (min)	Conc. range (ppb)	Linearity (r ²)	Rec. % (62.5ppb)	M.E % (62.5ppb)	RSD%(n=6) (62.5ppb)	S/N (2.5ppb)	LOD/LOQ (ppb)
Norpseudo-E	152.1	8.0	2.5 - 500	0.9982	97.3	69.3	1.67	11.3	0.71/2.17
Ephe	166.1	8.4	2.5 - 500	0.9960	84.4	111.0	0.54	33.7	0.25/0.76
Pseudo-E	166.1	9.0	2.5 - 500	0.9976	78.9	109.2	0.41	28.5	0.29/0.88
AMPH	136.1	9.6	2.5 - 500	0.9983	85.6	71.1	0.98	17.5	0.48/1.46
MAMP	150.1	10.2	2.5 - 500	0.9968	76.5	96.8	0.94	30.3	0.26/0.80
MDA	180.1	10.4	2.5 - 500	0.9989	71.8	70.3	1.94	18.2	0.45/1.36
MDMA	194.1	10.8	2.5 - 500	0.9973	72.2	116.3	1.08	36.6	0.23/0.70
MDEA	208.1	12.2	2.5 - 500	0.9908	74.8	107.1	2.18	41.9	0.19/0.57
Phent	150.1	12.4	2.5 - 500	0.9960	74.5	69.9	1.82	12.7	0.66/2.01
PAMP (Ref)	178.1	12.7	2.5 - 500	0.9912	69.5	96.8	5.30	37.7	0.22/0.66

Performance evaluation of on-line SPE-LCMS method

The trapping efficiency of the on-line SPE is critical and must be evaluated first, because it determines the recovery of the method. In this study, the recovery of the on-line SPE was determined by injecting a same mixed standard sample from a manual injector installed before the analytical column (by-pass on-line SPE) and also from the Autosampler (See Figure 1). The peaks areas obtained by the two injections were used to calculate recovery value of the on-line SPE method. As shown in Table 2, the recovery obtained with 62.5 ppb mixed standards are at 69.5% ~ 97.3%. The recovery with 250 ppb and 500 ppb mixed samples were also determined and similar results were obtained.

Matrix effect was determined with 62.5 ppb and 250 ppb levels of mixed samples in clear solution and in urine. The results (Table 2) show a variation between 69.3% and 116% with compounds. The matrix effect with different

urine specimens did not show significant differences. Repeatability was evaluated with spiked mixed samples of 62.5 ppb and 250 ppb. The results of 62.5 ppb is shown in Table 2, RSD between 0.41% and 5.3%. The sensitivity of the on-line SPE-LC/MS method was evaluated with spiked sample of 2.5 ppb level. The SIM chromatograms are shown in Figure 4. The S/N ratios obtained ranged 11.3~42, which were suitable to determine LOQ (S/N = 10) and LOD (S/N = 3). Since the urine samples were diluted for 10 times with water before injection, the LOD and LOQ of the method for source urine samples were at 1.9~7.1 and 5.7~21.7 ng/mL, respectively. The confirmation cutoff values of the five targeted amphetamines (Group A) in urine enforced by the new SMAHSA guidelines are 250 ng/mL [2]. The on-line SPE-LC/MS method established has sufficient allowance in terms of sensitivity and confirmation reliability for analysis of actual urine samples.

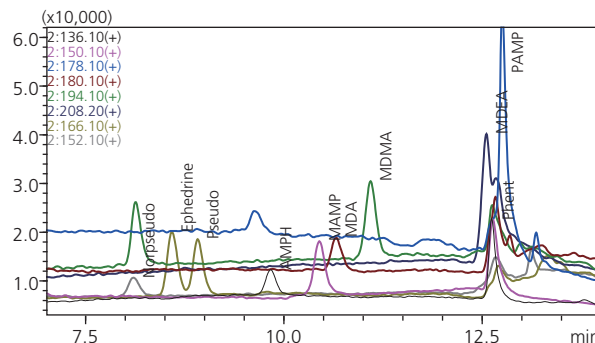

Figure 4: SIM chromatograms of 10 compounds with 2.5 ppb each by on-line SPE-LC/MS method.

Simultaneous Screening and Quantitation of Amphetamines in Urine by On-line SPE-LC/MS Method

Durability of on-line SPE trapping column

The durability of the trapping column was tested purposely by continuous injections of spiked urine samples (125 ppb) for 200 times in a few days. Figure 5 shows the chromatograms of the first and 200th injections of a same

spiked sample. The results show that the variations of peak area and retention time of the 200th injection compared to the 1st injection were at 89.5%~117.8% and 89.5%~99.8% respectively.

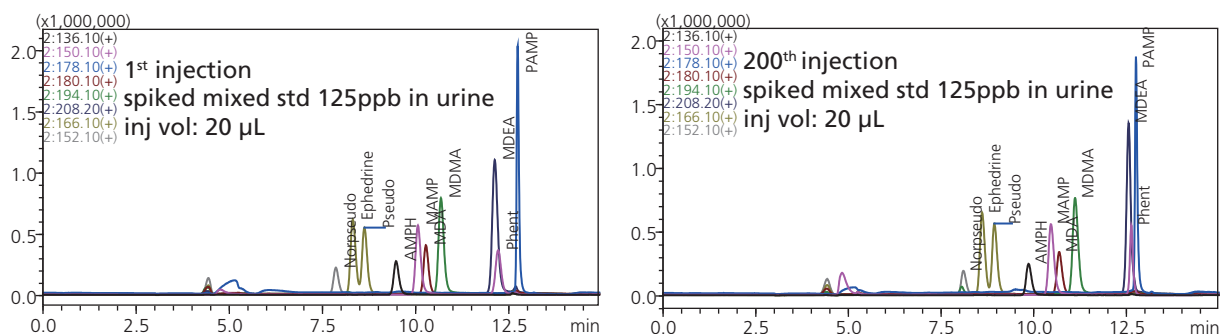

Figure 5: Durability test of on-line SPE-LC/MS method, comparison of 1st and 200th injections.

Confirmation Reliability

Confirmation reliability of LC/MS and LC/MS/MS methods must be proven to be equivalent to the GC/MS method according to the SMAHSA guidelines [2]. Validation of confirmation reliability of the on-line SPE-LC/MS method has not been carried out systematically. The high sensitivity of MS detection in SIM mode is a key factor to ensure no false-negative and the scan spectra acquired

simultaneously is used for excluding false-positive. In this work, the confirmation reliability was evaluated using five different urine specimens as matrix to prepare spiked samples of 2.5 ppb (correspond to 25 ng/mL in source urine) and above. The results show that false-positive and false-negative results were not found.

Conclusions

A novel high sensitivity on-line SPE-LC/MS method was developed for screening, confirmation and quantification of five amphetamines: AMPH, MAMP, MDMA, MDA and MDEA in urines. The recovery of the on-line SPE by employing a 50mL Synergi Polar-RP column was at 72%~86% for the five amphetamines, which are considerably high if comparing with conventional on-line

SPE cartridges. The method performance was evaluated thoroughly with urine spiked samples. The results demonstrate that the on-line SPE-LC/MS method is suitable for direct analysis of the amphetamines and relevant compounds in urine samples without off-line sample pre-treatment.

Simultaneous Screening and Quantitation of Amphetamines in Urine by On-line SPE-LC/MS Method

References

1. Kudo K, Ishida T, Hara K, Kashimura S, Tsuji A, Ikeda N, J Chromatogr B, 2007, 855, 115-120.
2. SAMHSA "Manual for urine laboratories, National laboratory certification program", Oct 2010, US Department of Health and Human Services.