

# No. M304A

## Determination of Chemical Species in Marine Fuel Oil in accordance with ASTM D 7845 by GC-MS

Fuel oil, also known as marine fuel oil, is a fraction obtained through petroleum distillation. Despite its widespread use in marine fuel pumps, contamination with compounds such as phenols has caused fuel pump malfunctions in recent years. ASTM D7845 provides standardized analytical methods for 30 aromatic and oxygenated compounds in marine fuel oil.

In this article, the quantitation of aromatics and oxygenates in marine fuel oil was conducted as per ASTM D7845 using a Shimadzu GCMS-QP™2020 NX.

Y. Higashi, Y. Nagao

### System configuration

The system was configured to replicate "Configuration B" of ASTM D7845.

A four-way connector was used to split the column flow into the MS and FID detectors (Fig. 1). High boiling components were backflushed at the end of each run. A VSD tubing (1 m × 0.15 mm ID, Trajan Scientific and Medical) was used as a restrictor between the four-way connector and FID. Topaz 1.5-mm ID straight inlet liner (Restek Corp., Cat. #23472) was used in a PTV inlet.

**Table 1 System configuration**

Model	: GCMS-QP 2020 NX/AOC -20 i Plus
Injection Port	: PTV -2030
Detector	: MS/FID -2030
Detector splitting unit	
1 <sup>st</sup> Column	: SH-1 (30 m × 0.25 mm ID, df = 0.25 μm) *1
2 <sup>nd</sup> Column	: SH-5MS (60 m × 0.32 mm ID, df = 0.5 μm) *2
Restrictor	: VSD tubing (1.0 m × 0.15 mm ID)

\*1 P/N: 221-75719-30

\*2 P/N: 227-36126-02

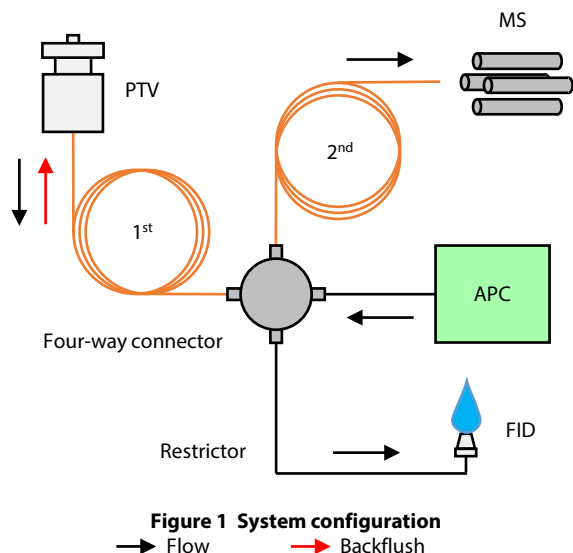

### Analysis conditions

Analysis conditions were set based on ASTM D7845 (Table 2). Advanced Flow Technology Software was used to set the column flow rate and the pressure programs. The inlet pressure was reduced at the end of each run to implement a backflush.

The high boilers were quickly discharged from the split vent during the backflush phase. The backflush start time was determined based on the elution time of n-hexadecane at the FID (Fig. 2)

**Table 2 Analysis conditions**

Injection Volume	: 0.5 μL
Injection Temp.	: 200 °C (14 min) –200 °C/min –400 °C (9 min)
Carrier Gas	: He
Carrier Gas Control	: Pressure, 260 kPa (19.5 min) - -400 kPa/min - 15 kPa (3.89 min)
Total flow rate	: 35 mL/min
Split flow rate	: About 25 mL/min *1
Purge gas	: 3.0 mL/min
Column Temp.	: 50 °C (2 min) –7 °C/min –200 °C
APC pressure	: 103 kPa
FID Temp.	: 240 °C
H <sub>2</sub> flow rate	: 32 mL/min
Air flow rate	: 200 mL/min
Makeup flow rate	: 24 mL/min (He)
Ion source Temp.	: 200 °C
Interface Temp.	: 250 °C
Tuning mode	: High concentration mode
Ionization method	: EI
Measurement mode	: Scan/SIM(FAAST mode)
Event time	: Scan 0.1 s/SIM 0.2 s

\*1 The split flow rate is set based on the total flow rate, the column inlet pressure and the column length.

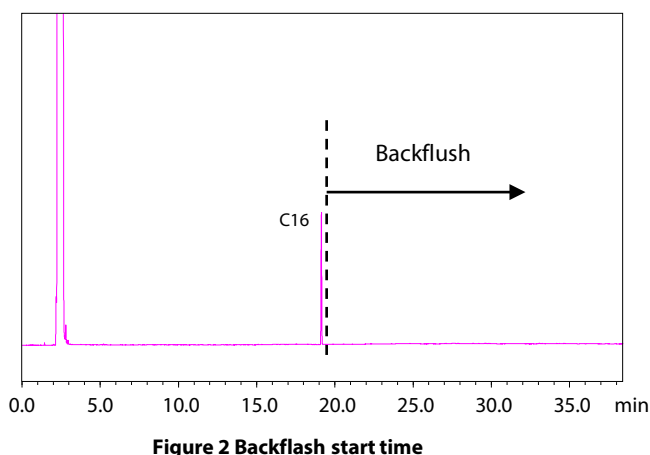

■ **Sensitivity test**

It is necessary for  $m/z=104$  of styrene to have a S/N of  $>5$  when measured at a concentration of 1 mg/kg. A S/N of approximately 1300 was obtained during this experiment and the chromatogram is shown in Fig. 3 below.

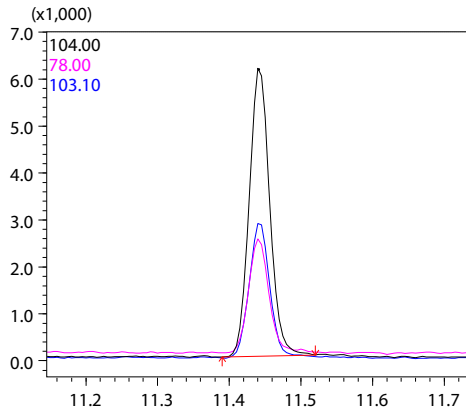

Figure 3 Styrene (1 mg/kg)

■ **Analysis of standard**

The same standard used in the system sensitivity test described above was analyzed consecutively ( $n = 5$ ). Its TIC chromatogram is shown in Fig. 4. A summary of the analytical results can be found in Table 3. The monitoring ions for quantitation and confirmation were specified in the ASTM. Compound #25 is the sum of 3-ethyl phenol and 4-ethyl phenol. Ethylbenzene-d 10 was used as an internal standard. The reproducibility of each compound was calculated and deemed acceptable.

Figure 5 lists a few examples of the calibration curves drawn in this experiment. ASTM recommends  $R^2$  be greater than 0.90 or preferably even greater than 0.99. All compounds analyzed in this experiment had an  $R^2$  of  $> 0.99$ , as shown in Table 3.

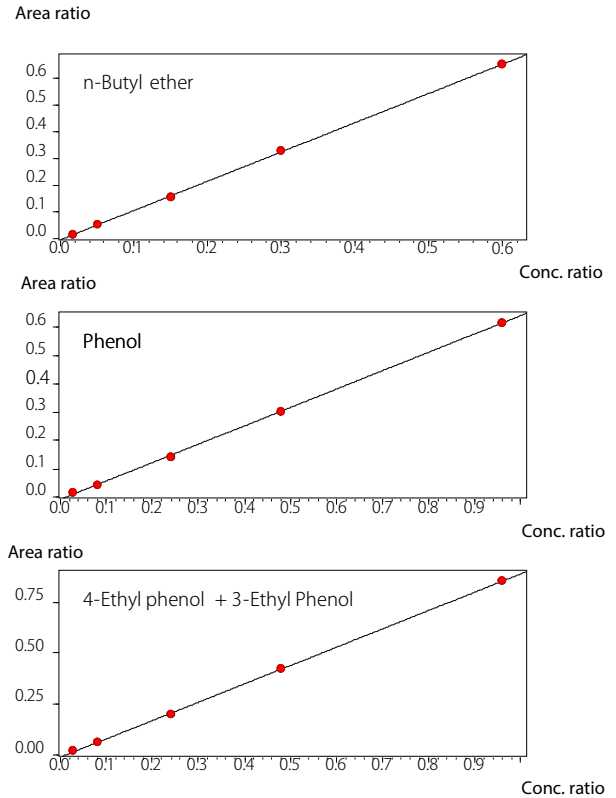

Figure 5 Calibration curves

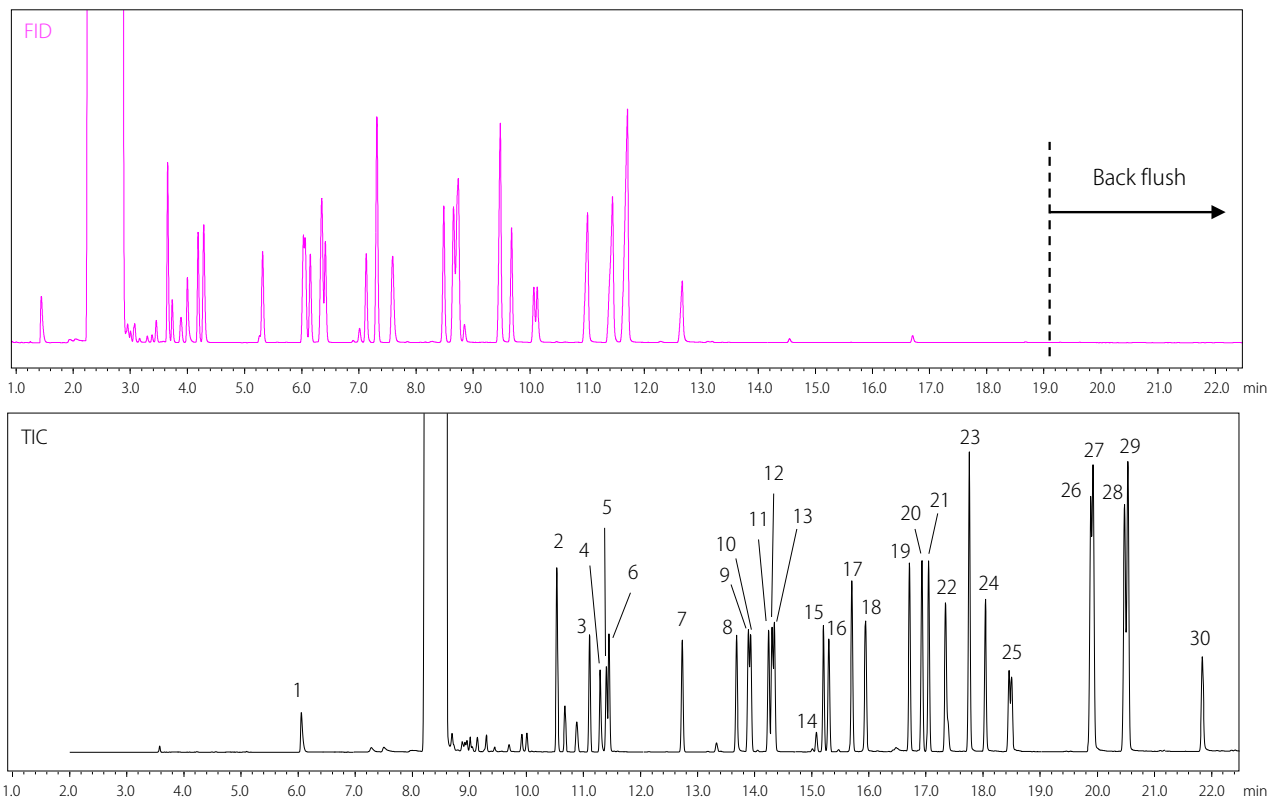

Figure 4 STD5 chromatograms (top: FID, bottom: MS TIC)

**Table 3 Area ratio reproducibility of standard solutions (n = 5) at each calibrator point and their corresponding squares of correlation coefficients (R<sup>2</sup>)**

#	Compound name	Concentration mg/kg					Area ratio RSD% (n = 5)					R <sup>2</sup>
		STD1	STD2	STD3	STD4	STD5	STD1	STD2	STD3	STD4	STD5	
1	1-Butanol	8.3	25	75	150	300	0.43	0.48	0.33	0.41	0.23	0.9982
2	Ethylbenzene-d10 (IS)	500	500	500	500	500			-			-
3	n-Butyl ether	8.3	25	75	150	300	0.67	0.23	0.22	0.16	0.18	0.9998
4	Cyclohexanol	8.3	25	75	150	300	1.1	0.99	0.15	0.17	0.31	0.9996
5	n-Butyl acrylate	8.3	25	75	150	300	1.4	1.3	0.36	0.24	0.22	0.9997
6	Styrene	8.3	25	75	150	300	0.37	0.12	0.21	0.19	0.31	0.9998
7	α-Pinene	8.3	25	75	150	300	0.40	0.24	0.11	0.11	0.29	0.9998
8	Phenol	13	40	120	240	480	1.4	0.62	0.30	0.16	0.35	0.9996
9	α-Methyl styrene	8.3	25	75	150	300	1.05	0.19	0.45	0.46	0.66	0.9998
10	β-Pinene	8.3	25	75	150	300	0.49	0.20	0.11	0.12	0.34	0.9999
11	3-Methyl styrene	8.3	25	75	150	300	1.3	0.22	0.33	0.48	0.53	0.9997
12	2-Methyl styrene	8.3	25	75	150	300	2.2	0.46	0.85	2.97	3.31	0.9996
13	4-Methyl styrene	8.3	25	75	150	300	3.0	0.66	0.92	3.7	4.4	0.9996
14	trans-β-Methyl styrene	8.3	25	75	150	300	1.6	0.35	0.29	0.27	0.29	0.9997
15	D-Limonene	13	40	120	240	480	0.54	0.39	0.25	0.20	0.30	0.9998
16	Dicyclopentadiene	8.3	25	75	150	300	0.38	0.48	0.25	0.20	0.23	0.9998
17	Indene	13	40	120	240	480	0.50	0.39	0.25	0.11	0.28	0.9998
18	1-Phenyl ethanol	13	40	120	240	480	2.4	0.63	0.54	0.22	0.30	0.9997
19	p, α-Dimethyl styrene	13	40	120	240	480	0.54	0.31	0.26	0.20	0.19	0.9999
20	2,5-Dimethyl styrene	13	40	120	240	480	0.49	0.42	0.39	0.16	0.23	0.9999
21	2,4-Dimethyl styrene	13	40	120	240	480	0.50	0.37	0.28	0.19	0.18	0.9998
22	2-Phenyl ethanol	13	40	120	240	480	0.64	0.40	0.33	0.09	0.34	0.9998
23	2-Ethyl phenol	28	83	250	500	1000	0.83	0.60	0.40	0.15	0.29	0.9998
24	2,4-Dimethyl phenol	13	40	120	240	480	3.9	0.76	0.37	0.17	0.34	0.9999
25	4-Ethyl phenol+3-Ethyl phenol	13	40	120	240	480	0.90	0.49	0.34	0.14	0.27	0.9998
26	2-Phenoxy ethanol	28	83	250	500	1000	2.2	0.62	0.34	0.16	0.45	0.9998
27	4-Isopropyl phenol	28	83	250	500	1000	0.95	0.46	0.26	0.19	0.30	0.9998
28	1-Phenoxy-2-propanol	28	83	250	500	1000	2.22	0.79	0.50	1.9	1.8	0.9996
29	2-Phenoxy-1-propanol	28	83	250	500	1000	2.1	0.68	0.38	1.40	0.90	0.9999
30	Styrene glycol	13	40	120	240	480	1.7	0.91	0.67	0.34	0.20	0.9989

### ■ Analysis of marine fuel oil sample

To prepare a 1000 mg/kg internal standard solution, ethylbenzene-d 10 was dissolved in toluene. Marine fuel oils A and B were weighed separately, and each oil was diluted twice with the IS solution. The diluted oils are designated as samples A and B hereafter.

A total of 13 out of the 30 target compounds were detected in sample A at concentrations greater than the higher limit of quantitation (i.e., the highest calibrator point). Sample B, by contrast, had 7 such compounds (Fig. 6). Phenol (# 8) was found at a 6-times higher concentration in A than B, whereas indene (#17) was 42-times higher in A than B.

The results showed wide amounts of variation in the aromatics and oxygenates among the samples. As an example, the MS chromatograms of 3 compounds (i.e., styrene, phenol, and dicyclopentadiene) are shown in Fig. 7, and the quantification results are shown in Table 4. A good reproducibility was also confirmed with the samples.

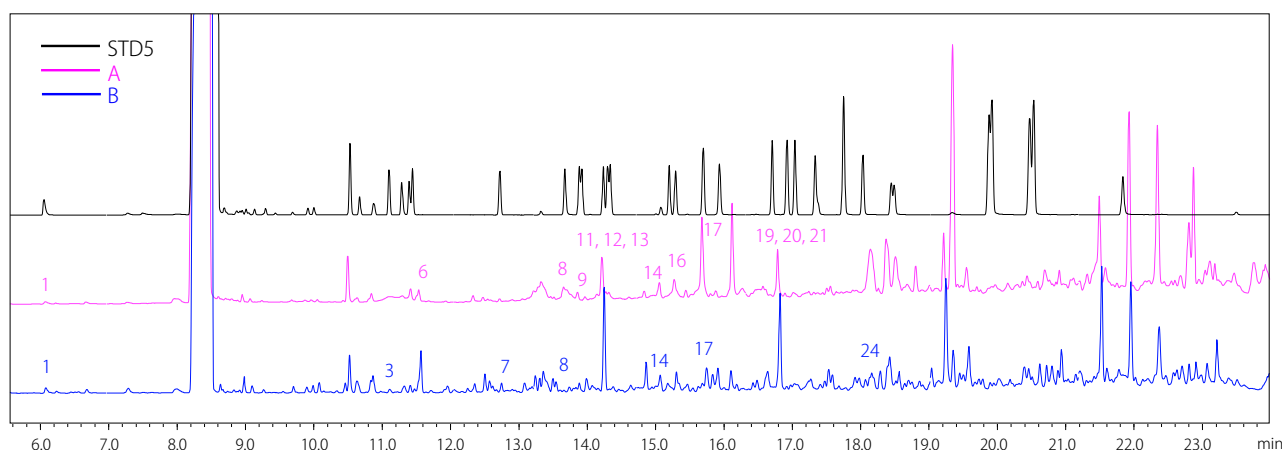

**Fig. 6 TIC chromatograms of STD5, sample A and sample B**  
The numbers on the peaks are the serial number in the elution order for the detected targets.

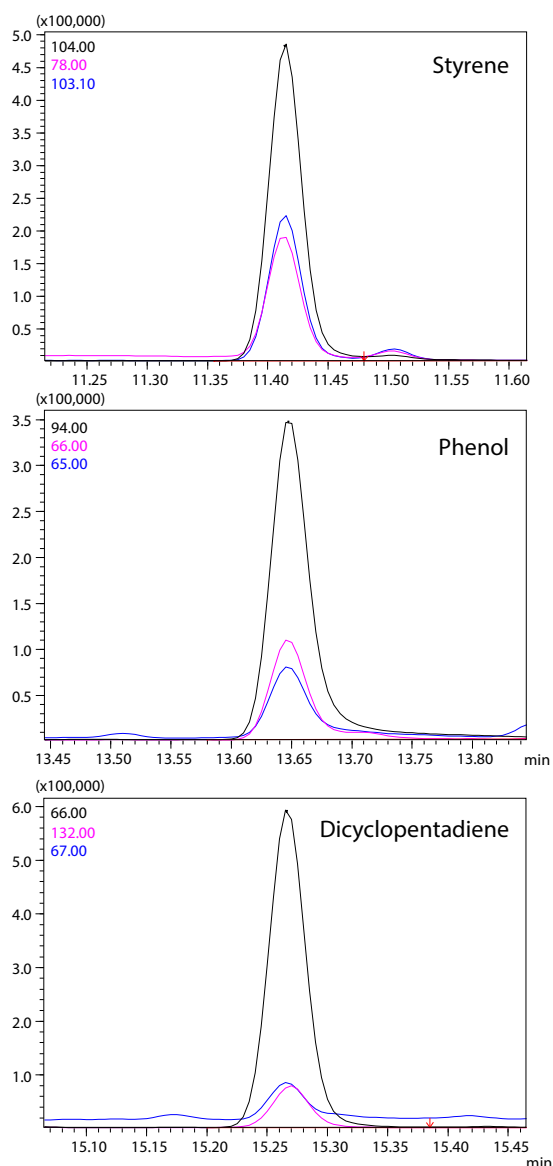

Figure 7 SIM chromatograms of sample A

Table 4 Quantitative results of sample A

	RT (n = 5)	Area ratio (n = 5)	Area ratio RSD%	mg/kg
Styrene	11.4	0.165	1.5	108
Phenol	13.6	0.147	0.89	120
Dicyclopentadiene	15.3	0.221	0.23	84

### Carryover test

A frequent replacement of inlet glass inserts is recommended in this analysis because this system configuration specified in ASTM is prone to contamination with high boilers remaining in and around the inlet. A liner replacement of every 10 to 20 injections is recommended by ASTM. To calculate a carryover, a toluene blank reagent was applied after 10 consecutive runs of sample A. Fig. 8 overlays the three SIM chromatograms (i.e., STD 1, sample A, and toluene reagent blank) for Indene, which was found at the highest concentration among the target components detected in sample A. The toluene reagent blank at the end of the batch had only approximately 3% of the Indene peak intensity compared to that of STD 1 (i.e., a low calibrator point) and no quantifiable peak was observed. The remaining compounds listed in Table 3 also show no carryovers.

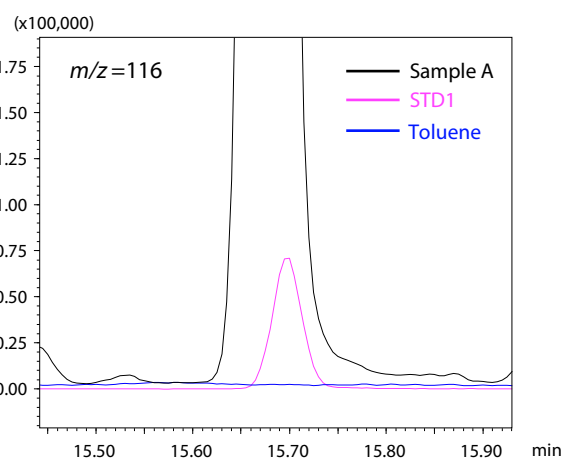

Figure 8 Overlaid SIM chromatograms of Indene with quantitative ion of  $m/z = 116$

### Summary

GCMS-QP2020 NX was used to quantitate aromatic and oxygenated compounds in marine fuel oil according to ASTM D7845. The system sensitivity test showed an excellent result with a S/N of approximately 1300, in which >5 was required. The configured system also proved to be fit with the sample analysis. The simultaneous SIM/Scan (i.e., FFAST) mode used in this experiment was useful in determining the presence of contaminants.

Thus, GCMS-QP2020 NX is an excellent instrument choice for quantifying aromatic and oxygenated compounds in marine fuel oils according to ASTM D7845.

GCMS-QP is a trademark of Shimadzu Corporation or its affiliated companies in Japan and/or other countries.  
Topaz is either a trademark or a registered trademark of Restek Corporation in the United States and/or other countries.



Shimadzu Corporation  
www.shimadzu.com/an/

For Research Use Only. Not for use in diagnostic procedures.

This publication may contain references to products that are not available in your country.

Please contact us to check the availability of these products in your country.

The content of this publication shall not be reproduced, altered or sold for any commercial purpose without the written approval of Shimadzu. See <http://www.shimadzu.com/about/trademarks/index.html> for details.

Third party trademarks and trade names may be used in this publication to refer to either the entities or their products/services, whether or not they are used with trademark symbol "TM" or "®".

Shimadzu disclaims any proprietary interest in trademarks and trade names other than its own.

The information contained herein is provided to you "as is" without warranty of any kind including without limitation warranties as to its accuracy or completeness. Shimadzu does not assume any responsibility or liability for any damage, whether direct or indirect, relating to the use of this publication. This publication is based upon the information available to Shimadzu on or before the date of publication, and subject to change without notice.

First Edition: Dec. 2020  
Revision A: Mar. 2023